

	<h1>Engineering Standard</h1>	Doc Number: ES0001	Issue: 4
	Title: Custom Flywheel and Clutch Design Data Form	Author: SRV	Effective Date: 28/11/23

Fill in form then scan / photo and email to: info@ttvracing.com

Name:			Address:
Company:			
Email:			Telephone:
Vehicle/Engine:			Torque: Lb Ft <input type="checkbox"/> Nm <input type="checkbox"/>
Gearbox Type:			2WD <input type="checkbox"/> 4WD <input type="checkbox"/>
Spline Details:			
Clutch Details:			
Application:	(Circuit, Rallycross, etc.)		

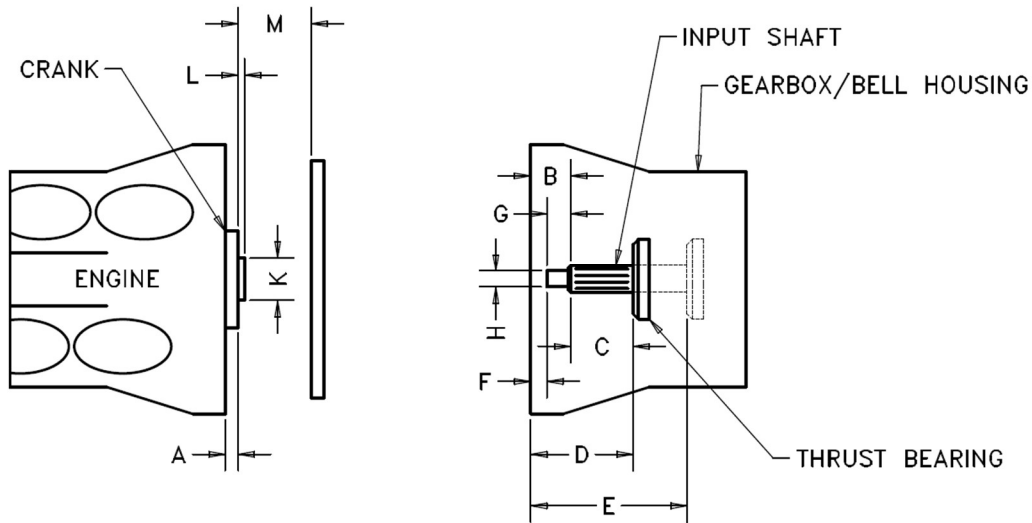

A	Dimension from crank face to block where bell housing mates (minus value is to be left of block mounting face)		mm
B	Dimension from bell housing face to start of spline		mm
C	Length of spline		mm
D	Dimension from bell housing face to thrust bearing fully forward		mm
E	Dimension from bell housing face to thrust bearing fully backwards		mm
F	Dimension from bell housing face to start of pilot		mm
G	Length of pilot		mm
H	Diameter of pilot		mm
J	Thickness of gearbox adaptor plate (if fitted)		mm
K	Diameter of crank spigot		mm
L	Length of crank spigot		mm
M	Dimension from crank face to ring gear (minus value is to be left of crank face)		mm



Please advise if there are any restrictions within the bell housing which could foul the clutch assembly. It is advisable to supply us with an OEM flywheel that matches the starter motor being used. This is so we can ascertain the correct number of teeth and tooth form (including lead-in chamfers).

Starter Motor Pinion Entry	Engine Side <input type="checkbox"/>	Release Bearing Type	Round Face <input type="checkbox"/>	Bearing / Fulcrum Diameter (mm)
	Gearbox Side <input type="checkbox"/>		Flat Face <input type="checkbox"/>	

PLEASE ADD ADDITIONAL SHEETS IF MORE INFORMATION NEEDS TO BE SUPPLIED

Our "Supply of Goods Terms & Conditions" can be found on our website under "Info & Downloads".

TTV Racing parts are designed for motorsport requirements only and have not been designed/ tested/ homologated for road use. Installation of these parts may void vehicle manufacturers warranty coverage and/ or may cause the vehicle to be illegal in some countries. Please check with local laws on the road use of your vehicle. TTV Racing reserves the right to make product improvements and changes without notice.